

CNC lineare encoder
 V 0.9 Preliminair

Male DB-9

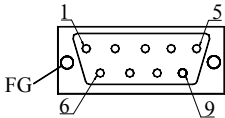

1	2	3	4	5	6	7	8	9
	GND				A	+5V	B	Z

TTL

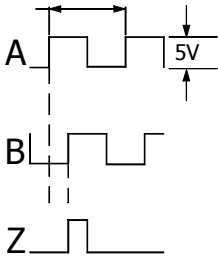

EIA-442-A

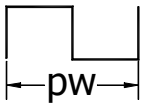
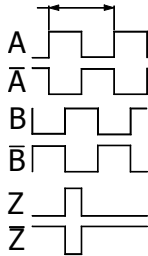

Resolutie	pw
5µm	20µm
1µm	4µm

CNC lineare encoder
V 0.9 Preliminair

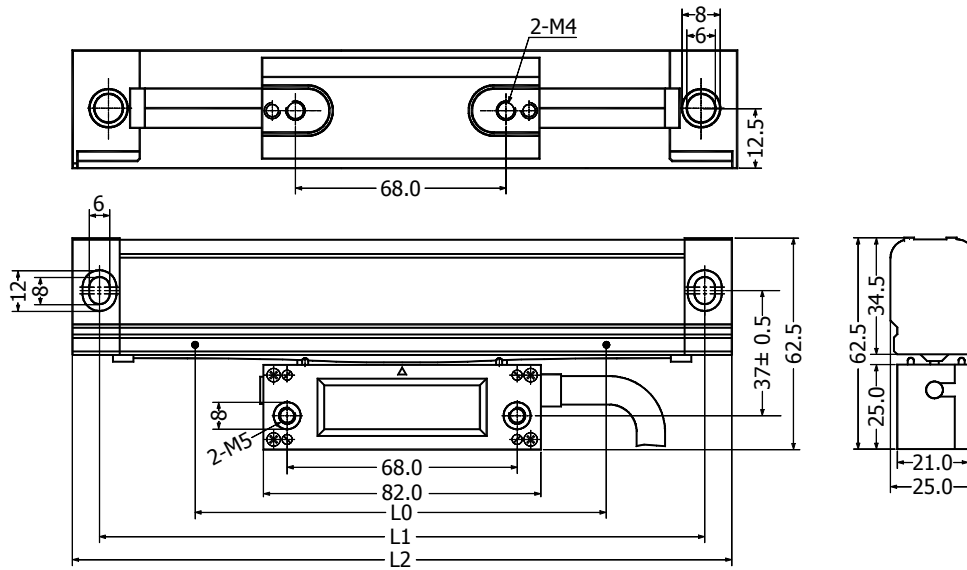

	L0	L1	L2		L0	L1	L2
LENGHT-70	70	160	176	LENGHT-570	570	660	676
LENGHT-120	120	210	226	LENGHT-620	620	710	726
LENGHT-170	170	260	276	LENGHT-670	670	760	776
LENGHT-220	220	310	326	LENGHT-720	720	810	826
LENGHT-270	270	360	376	LENGHT-770	770	860	876
LENGHT-320	320	410	426	LENGHT-820	820	910	926
LENGHT-370	370	460	476	LENGHT-870	870	960	976
LENGHT-420	420	510	526	LENGHT-920	920	1010	1026
LENGHT-470	470	560	576	LENGHT-1020	1020	1110	1126
LENGHT-520	520	610	626				